

**PYTHAGOREAN "RULE" AND
"THEOREM" – MIRROR OF THE
RELATION BETWEEN BABYLONIAN
AND GREEK MATHEMATICS**

JENS HØYRUP

**FILOSOFI OG VIDENSKABSTEORI PÅ
ROSKILDE UNIVERSITETSCENTER**

3. Række: Preprints og reprints

1998 Nr. 3

Contents

The Greek theorem	2
The Old Babylonian evidence	4
The status of the rule	9
Geographical distribution	11
Transmission and transformation	13
Whence?	14

Abbreviations

The ideas of the following paper were first presented as a guest lecture at Dipartimento di Filosofia & Dipartimento di Scienze storiche, filosofiche e geografiche, Università degli Studi di Lecce, and in final form at II. Internationales Colloquium der Deutschen Orient-Gesellschaft, Berlin, "Babylon: Focus mesopotamischer Geschichte, Wiege früher Gelehrsamkeit, Mythos in der Moderne". Since it is to be published in the proceedings of the latter meeting, it makes use of the following Assyriological standard abbreviations:

- AOAT: Alter Orient und Altes Testament.
AoF: *Altorientalische Forschungen* (Berlin).
JCS: *Journal of Cuneiform Studies*.
MCT: O. Neugebauer & A. Sachs, *Mathematical Cuneiform Texts*. (American Oriental Series, vol. 29). New Haven, Connecticut: American Oriental Society, 1945.
MDP: *Mémoires de la Mission Archéologique en Iran* (begun as *Mémoires de la Délégation en Perse*).
MKT: O. Neugebauer, *Mathematische Keilschrift-Texte*. I-III. (Quellen und Studien zur Geschichte der Mathematik, Astronomie und Physik. Abteilung A: Quellen. 3. Band, erster-dritter Teil). Berlin: Julius Springer, 1935, 1935, 1937.
RIA: *Reallexikon der Assyriologie und Vorderasiatischen Archäologie*. Berlin & New York: de Gruyter.
TMB: F. Thureau-Dangin, *Textes mathématiques babyloniens*. (Ex Oriente Lux, Deel 1). Leiden: Brill, 1938.
ZA: *Zeitschrift für Assyriologie und Vorderasiatische Archäologie*.

It was known at an early date that numbers and numerical computation played a major role in Babylonian social life and culture.¹ It could hardly be otherwise, given the importance of bureaucracy and bureaucratic control. None the less it came as an immense surprise when it was discovered from the late 1920s onwards that the contents of a number of tablets was mathematical in the proper sense, that is, that they dealt with mathematical problems that went beyond what could be anticipated as immediately necessary in accounting, area determination, manpower calculations and (relevant only in the late period) the description of planetary movements.² That mathematics on this level of virtuosity had been a Babylonian concern was indeed no historical necessity, as eminently illustrated by the case of Ur III. Thanks to Eleanor Robson's doctoral work³ we now know how mathematics teaching looked in the context of what was probably the most meticulous bureaucracy of world history: apart from scratch pads with numerical computations, the only mathematical school texts are model documents.⁴

Historians of mathematics were particularly struck by the Babylonian solution of second-degree equations (and, as discovered during the 1930s,

¹ An inclusive bibliography of publications which elucidate this aspect of Mesopotamian civilization is Friberg, J., "A Survey of Publications on Sumero-Akkadian Mathematics, Metrology and Related Matters (1854–1982)", Department of Mathematics, Chalmers University of Technology and the University of Göteborg No. 1982–17

² This discovery and its impact is described pp. 1–10 in Høyrup, J., "Changing Trends in the Historiography of Mesopotamian Mathematics: An Insider's View", *History of Science* 34 (1996), 1–32.

³ Robson, E., "Old Babylonian Coefficient Lists and the Wider Context of Mathematics in Ancient Mesopotamia, 2100–1600 BC", (Dissertation, submitted for D.Phil in Oriental Studies, Wolfson College, Oxford, 1995), 204–207.

⁴ That no autonomous interest in mathematics was present in Ur III could be suspected from indirect evidence, and seems to fit the particular situation of intellectual activity in the Ur III context – cf. Høyrup, J., *In Measure, Number, and Weight. Studies in Mathematics and Culture*, (New York, 1994), 61–63, 77–79. The coherence of the resulting picture (and the absence of later traces of any Neo-Sumerian terminology for the formulation of *problems*) suggests that the absence of problem texts from the UR III record is not due to the bad luck of excavations.

certain higher-degree equations). They had supposed algebra to be an invention of medieval India and Islam, somehow anticipated in Diophantos's *Arithmetic* and the "geometric algebra" of *Elements* II. The new discoveries led Neugebauer to formulate the thesis, soon accepted as unquestioned orthodoxy until c. 1970, that the "geometric algebra" was a translation of the results of Babylonian algebra into the language of geometry – a translation that had become mandatory after the discovery of irrationality.⁵

To a general public, unburdened by prejudice about the origin of algebra – not least thus the general public of Assyriologists – it was and remained more striking that even the theorem of Pythagoras appeared to have been known in the Old Babylonian period.⁶ After all, the theorem was linked to Greek mathematics not only by its name but also by the familiar anecdote, according to which *geschlachtet und verbrannt, Einhundert Ochsen* had been the price the famous philosopher paid to the gods for granting him the discovery.⁷

Since then, more than half a century has gone by, and the latest decades have produced a new image of Mesopotamian mathematics. None the less – or perhaps for the reason that this new picture has hardly reached the broader public – it may be profitable to return to the question about the relation between the Greek theorem and the knowledge of the Old Babylonian calculators.

The Greek theorem

Let us first look at the theorem and on the way it is proved in *Elements*

⁵See Neugebauer, O., "Zur geometrischen Algebra (Studien zur Geschichte der antiken Algebra III)". *Quellen und Studien zur Geschichte der Mathematik, Astronomie und Physik. Abteilung B: Studien* 3 (1934–36), 245–259; and the discussion in Høyrup, "Changing Trends ..." (note 2), 10, 16f.

⁶It was of course less astonishing that the theorem was used in texts from the Seleucid period. For the same reason I shall leave the Seleucid texts aside in what follows.

⁷"Vom pythagoreischen Lehrsatz", in: Chamisso, *Werke*, (Berlin & Weimar, 1988), 209.

I.47. The theorem tells that the sum of [the areas of] the two squares erected on the shorter sides of a right triangle equals [the area of] the square erected on the hypotenuse. The proof runs as follows in paraphrase (see Figure 1):⁸ The triangle is ABC , on whose sides the squares AD , AI and BF are erected; AG is drawn parallel to CF . According to Postulate 4, all right angles are equal, whence $\angle ACD = \angle BCF$. Moreover, if equal magnitudes be added to equals, equal magnitudes result (Common Notion 2). Therefore, if $\angle ACB$ be added to $\angle ACD$

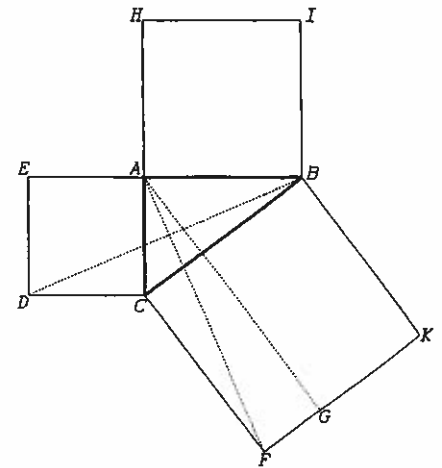

Figure 1

and $\angle BCF$, the resulting angles $\angle BCD$ and $\angle FCA$ will be equal. By the definition of the square (Definition 22), $AC = CD$ and $CF = CB$. Therefore, the triangles ACF and BCD are equal (Proposition I.4). Further, since a triangle is half the parallelogram contained by the same parallels and having the same base (Proposition I.41), ACF is half rectangle CG , and BCD is half the square AD , BAE being a straight line by the definition of a right angle (Definition 10) and parallel to CD by the definition of the square. Thus square AD equals rectangle CF .

But AG is also parallel to BK , BK and CF being parallel. By similar arguments we therefore get that square AI is equal to rectangle BG . Taken together, rectangles BG and GC – which amount to nothing but the square BF on the hypotenuse – thus equal the sum of the squares AD and AI on the shorter sides.

All this is far removed from anything we know from Old Babylonian mathematics (and even Seleucid mathematics, for that matter). It is a theorem, whereas the cuneiform texts contain nothing but paradigmatic

⁸ See, e.g., *The Thirteen Books of Euclid's Elements*, trans. E. Heath, 3 vols (Cambridge & New York, 1926), I, 349f.

examples, numerical determination of magnitudes, a few opaque attempts to formulate a general computational rule, and a couple of didactical expositions of the transformation of an equation. It deals with a triangle, whereas the basic configuration of the Babylonians would be the rectangle. And it argues explicitly about parallels, about the equality of angles and about other topics for which nothing suggests that the Babylonians would possess as much as a rudimentary terminology.

How is it then possible to claim that the Old Babylonian calculators (calling them "mathematicians" without further explanation is an anachronistic misnomer) knew the "theorem of Pythagoras"?

The Old Babylonian evidence

The claim is grounded on eight texts, three of which were known in the 1930s. The first of these is the problem BM 85196, obv. II.7-16.⁹ It deals with a pole of length 30' NINDAN,¹⁰ which at first stands against a wall, and whose upper end is then lowered 6' NINDAN (see Figure 2). The distance which the lower end moves outwards is

found to be $\sqrt{30'^2 - (30' - 6')^2} = \sqrt{30'^2 - 24'^2} = 18'$ NINDAN – in

agreement with what I shall henceforth speak of as the "Pythagorean rule", since this is how it occurs here

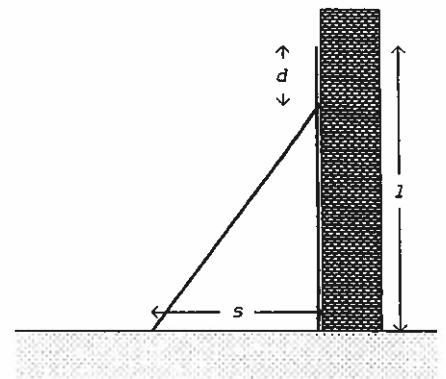

Figure 2. The reed standing and leaned against the wall.

⁹ Ed., trans. O. Neugebauer, MKT II, pp. 44, 47.

¹⁰ I use Thureau-Dangin's transcription of the Babylonian sexagesimal place value numbers, where ', '' etc. indicate decreasing and `', `` etc. increasing sexagesimal orders of magnitude. «°» (when needed) marks the order of simple integers – that is, $n^\circ = n$. Orders of absolute magnitude are my choice, when possible based on what seems reasonable: in the present case, it seems more plausible that the length of the rod be 3 m than either 180 m or 5 cm.

and elsewhere in the material. Next, the text finds how much the upper end will descend if the lower end moves 18' NINDAN outwards, according to the same rule.

The problem BM 85194, rev. I.33–43¹¹ deals with a circle and a chord – see Figure 3. The perimeter of the circle is told to be 1' NINDAN, from which the diameter D is seen without calculation to be 20 NINDAN; moreover, the arrow is $d = 2$ NINDAN. The chord is then found as $\sqrt{D^2 - (D - 2d)^2}$

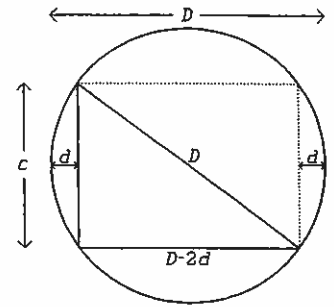

– or rather, if we express ourselves in terms that correspond to the text, as the “equal-side” (šb.Si₈, the side of the area if laid out as a square) of $\square(D) - \square(D - 2d)$.¹² Once again the calculation presupposes the Pythagorean rule, but it is based on a more sophisticated consideration – see the diagram. In lines 39–43, the arrow is determined instead from the diameter and the chord.

Figure 3. The circle of BM 85194 rev. I 33–43, with chord and descent.

VAT 6598, rev. I.19–II.4 (#6–7 in the enumeration of TMB)¹³ treats of a door with height $h = 40'$ NINDAN and width $w = 10'$ NINDAN. Two approximate formulae for the length of the diagonal are given: $d = h + \frac{\square(w)}{2h}$

in #6, $d = h + 2h\square(w)$ in #7.

¹¹ Ed., trans. O. Neugebauer, MKT I, pp. 148, 159f, cf. TMB, p. 32.

¹² The analysis of the texts that leads forward to this interpretation – in particular to the interpretation of *šutakūlum* (not *šutākulum*, the reference being *kullum* and not *akālum*; in the present text written with the logogram NIGIN) is presented in Høyrup, J., “Algebra and Naive Geometry. An Investigation of Some Basic Aspects of Old Babylonian Mathematical Thought”. AoF 17 (1990), 27–69, 262–354.

¹³ Ed., trans. O. Neugebauer, MKT I, pp. 279f, 282, cf. TMB, p. 130. A new edition and translation of the tablet, joined with the fragment BM 96957, is found in Robson, *op. cit.* (note 3), 269–280. Since the published version of this dissertation is still in press, I shall abstain from discussing the other problems of the text.

The formula of #6 is a fair (and familiar) approximation to $d = \sqrt{h^2 + w^2}$ if $d \gg w$, and can be argued from Figure 4: The area $\square(w)$ is distributed along two sides of $\square(h)$, that is, as two rectangles $\square(h, \frac{\square(w)}{2h})$. If we neglect that the small shaded square is missing, $\square(h) + \square(w)$ can thus be identified with $\square(h + \frac{\square(w)}{2h})$, and its square root with $h + \frac{\square(w)}{2h}$.

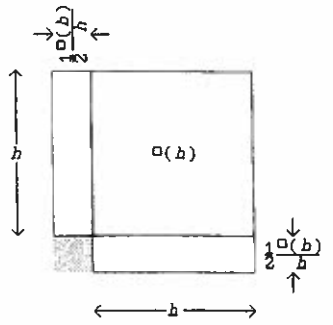

Figure 4. The probable geometrical reasoning behind VAT 6598 #6.

The formula of #7 is not only much less precise than that of #6¹⁴ but also absurd as it stands, adding a length and a volume (*problems* were certainly constructed by means of such operations, but in a formula to be used in computations it makes no sense). Neugebauer suggests¹⁵ that it

is an approximation to the formula $d = h + \frac{2w^2h}{2h^2 + w^2}$

, in which the divisor $2h^2 + w^2$ is, firstly, irregular and hence unhandy, and, secondly, close to 1 (namely 55'). He suggests¹⁶ that this formula will have been found as an approximation to the

complementary approximation $d_1 = \frac{\square(h) + \square(w)}{d_0}$,

where d_0 is the approximation $h + \frac{\square(w)}{2h}$ given in

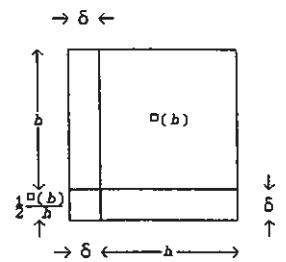

Figure 5. A possible geometrical procedure behind VAT 6598 #7.

¹⁴ 42'13''20''' instead of 41'15''. The true value is 41'13''51'''48''''... .

¹⁵ MKT I, pp. 286f.

¹⁶ Via a reference to Neugebauer, O., *Vorgriechische Mathematik*, (Berlin, 1934), 35f.

#6. The choice of operations (a “doubling”/TAB in #7, which inverts the “breaking”/hepûm of #6) makes it more likely, however, that this second approximation builds on a further elaboration of the geometric argument. If we look at Figure 5 we notice that the area $\square(w)$ should not be distributed along the edges of $\square(h)$ alone but as two rectangles $\square(h, \delta)$ and a square $\square(\delta)$, which can be put together as a single rectangle $\square(2h + \delta, \delta)$; since δ is already small compared to $2h$, the length of this rectangle is very close to $2h + \frac{1}{2} \frac{\square(w)}{h}$, whence $\square(w) = \square(2h + \frac{1}{2} \frac{\square(w)}{h}, \delta)$; reversion of the operations

by which $\frac{1}{2} \frac{\square(w)}{h}$ was derived yields $\square(\delta, 4\square(h) + \square(w)) = 2\square(w) \cdot h$;

if we forget to divide by $4\square(h) + \square(w)$ ($1^\circ 48' 20''$, an irregular and unpleasant divisor), this leads to $\delta = \square(w) \cdot h$, as indicated by the text.

Among the mathematical texts from Susa, two make use of our rule. Text I¹⁷ is a drawing of a doubled 30° - 40° - 50° -triangle inscribed in a circle. The sides of this triangle evidently constitute the starting point, which means that the radius r of the circumscribed circle – correctly stated as $31' 15''$ – has been calculated. The tablet does not tell how, but the only plausible way is by means of the Pythagorean rule (Greek practical geometry might use instead the proportion $40':30'::30':(2r-40')$, but no trace of such considerations can be found in the Old Babylonian corpus). From the rule follows that

$$\square(r) = \square(30') + \square(40' - r),$$

which can be transformed into

$$\square(r) - \square(40' - r) = \square(30').$$

Either by means of something like Figure 7 (a “naive” version of *Elements*

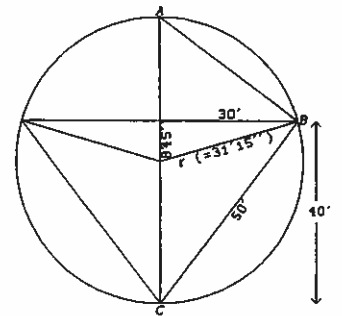

Figure 6. Redrawing of the triangle with circumscribed circle from TMS I

¹⁷ Edition and discussion E. M. Bruins & M. Rutten, MDP 34, pp. 22f, pl. 1.

II.7) or from a similar configuration where the smaller square is located concentrically within the greater one this leads to

$$(2 \cdot 40') \times (r - 20') = 15',$$

from which $r = 31'15''$ follows without difficulty.

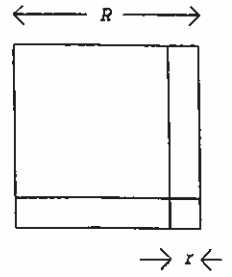

Figure 7. Diagram from which "pro-to-Elements II.7" follows.

The other relevant Susa text is No XIX,¹⁸ which contains two problems about a rectangle with a diagonal. In #1, the width w is told to be $\frac{1}{4}$ less than the length l , and the diagonal d is given to be $40'$. The solution follows from a "false position" $l = 1$, which implies that $w = \frac{3}{4}$ and hence, using the Pythagorean rule, $d = 1'15'$. The true values must therefore be reduced by a factor $\frac{40'}{1'15'} = 32'$.

#2 is much more complex. The area $\square(l, w)$ is given to be $20'$; moreover, we are told the area of another rectangle, one side of which is d , while the other is $\square(l)$, the cube on the length of the original triangle.¹⁹ The sophisticated procedure that leads to the solution once again makes (implicit) use of the transformation $\square(d) = \square(l) + \square(w)$.

The tablet Plimpton 322²⁰ is a table, not directly of Pythagorean triples $a - b - c$ (that is, number triples fulfilling the condition $a^2 + b^2 = c^2$) but of $???\bar{c}^2 - b - c$, where ??? stands for one or (probably) more lost columns and

$\bar{c} = c/a$. All pairs $(\bar{b}, \bar{c}) = (\frac{t' - t}{2}, \frac{t' + t}{2})$ are listed for which $\sqrt{2} - 1 < t < \frac{5}{9}$, t being

the ratio between two "regular" numbers no greater than 125, $t' = 1/t$. The heads of the columns show that the numbers are understood as having to do with the [length,] width and diagonal of a rectangle. For the rest,

¹⁸ Edition and relatively adequate translation and commentary E. M. Bruins & M. Rutten, MDP 34, pp. 101-105.

¹⁹ That (the volume of) a geometrical cube is meant follows from the distribution of the operations.

²⁰ Ed. Neugebauer & Sachs, MCT, pp. 39-41.

the purpose of the table is an enigma, and none of the explanations suggested so far seem plausible.²¹ For our present purpose it is sufficient to notice that the text presupposes both knowledge of the Pythagorean rule and of techniques for creating Pythagorean triples (directly or via some equivalent).

All texts referred to so far used the rule correctly; one, however, misapplies it: YBC 8633. It deals with an isosceles triangle, whose legs ("both lengths" /UŠ) are 1'40, whereas the base (the "width" /SAG) is 2'20; the area is to be found. The tablet contains a drawing, which is redrawn in correct proportions in Figure 8. The text takes the legs to be hypotenuses in (right) triangles with sides 1', 1'20 and 1'40 (obtained by blowing up the 3-4-5-triangle with a factor 20), and supposes erroneously that these are located within the original triangle as shown in the figure. This procedure does not directly presuppose familiarity with the Pythagorean rule, only the knowledge that the area of a 3-4-5-triangle is $(\frac{1}{2} \cdot 3) \cdot 4$ – or, equivalently, that a rectangle with sides 3 and 4 has diagonal 5; this knowledge could easily be transmitted with the standard IGI.GUB table independently of the underlying principle.

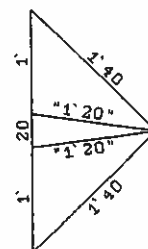

Figure 8. The triangle of YBC 8633.

The status of the rule

Neither in the latter misapplication nor in any of the other texts do we find any trace of an explicit *theorem*, nor an enunciation of the rule as an abstract principle. However, several of the examples (in particular Plimpton 322 with its coupling to the construction of Pythagorean triples) leave no doubt that both explicit knowledge of a general *rule* and of some kind of underlying principle was present.

²¹ See Friberg, J., "Methods and Traditions of Babylonian Mathematics, II: An Old Babylonian Catalogue Text with Equations for Squares and Circles". JCS 33 (1981), 57–64. Friberg's own proposal – that the table be meant to provide parameters from which second-degree equations can be constructed – does not fit the Old Babylonian habit of constructing problems from known very simple solutions – mostly the rectangle 20×30 or the square 30×30.

But *which* rule, and which principle? Which is the figure for which the rule was supposed to hold? All that can be concluded from the texts is that it was used for configurations (whether quadrangular or triangular) that are sufficiently defined by one length and one width, the product of which determines the area of the figure in question.

From our point of view, such figures must be rectangles if quadrangular, and right if triangular. However, the definition of these figures seems to presuppose the notion of the right angle, and thus confronts us with the recurrent claim that the Babylonians did not possess the concept of the angle.²² Of these three examples, only Gandz explains precisely which of many versions of the concept is intended when *the* concept is spoken of – namely the “angle as a measurable quantity in the modern or Greek sense of the word” (p. 416). Thureau-Dangin’s tacit understanding may have been similar, but Bruins, when quoting it, takes it to imply that, *a fortiori*, the notion of triangles having the same angles was unknown to the Babylonians – neglecting that similarity (“having the same shape”, corresponding to the Euclidean notion of being “given in shape”) may be a primitive and not a derived notion (as it has become in Euclid’s *Data*, Def. 3).

If Bruins was right, the Babylonians would have had to believe that the Pythagorean rule held true for any trapezium and for any triangle (and that the area of all such figures was determined from length and width alone). This seems absurd, and already architectural evidence shows the affirmation to be nonsensical that the Babylonians had no understanding of angles. We should distinguish the absence of a notion of the *angle as a measurable quantity* from inability to perceive a difference between different angles.

For the present purpose all we need to notice is that the Babylonians distinguished what we would call the “right” from what we may designate a “wrong” angle – that is, between corners whose legs when multiplied determine an area and such corners which do not serve this purpose. This

²² See, for instance, F. Thureau-Dangin, *TMB*, p. xvii; Gandz, S., “Studies in Babylonian Mathematics II. Conflicting Interpretations of Babylonian Mathematics”, *Isis* 31 (1939), 405–425; and E. M. Bruins, *MDP* 34, p. 4.

distinction is evident in field plans, where right angles are rendered as right angles, while no care is taken to render the irrelevant “wrong” angles with quantitative precision. Similar evidence is offered by the “geometric” text BM 15285.²³ The Greek contribution was not to discover that corners may be different, and that some of them can be singled out as “right”, but to introduce an explicit *definition*: “When a straight line set up on a straight line makes the adjacent angles equal to one another, each of the equal angles is right”,²⁴ and to discover in the second instance that this definition is useless unless supported by the postulate that “all right angles are equal to one another”.²⁵

We notice that all occurrences of the Pythagorean rule discussed above concern precisely angles that are right in the sense of being “non-wrong”, with the exception of the misapplication not of *the rule as such* but of the 3-4-5-triangle in YBC 8633; this leaves little doubt that this was the situation where it was supposed to hold true.

Geographical distribution

In 1945, Goetze attempted to determine the geographical origin of the Old Babylonian mathematical texts published in MKT and MCT;²⁶ since almost all of them had been bought on the antiquities market, he based the classification on orthography and, to some extent, on vocabulary. He found six text groups, of which Nos 1–4 could be assigned to “the South”, that is, the former Sumerian heartland (group 1 and perhaps group 2 probably coming from Larsa, groups 3 and 4 from Uruk), and 5–6 to “the North” (group 6 coming in all likelihood from Sippar²⁷). Since then, a fair number of texts with known provenience have been published, some from

²³ The most complete edition to date is in Robson, *op. cit.* (note 3), pp. 248–256.

²⁴ *Elements* I, Def. 10, trans. Heath (note 8) I, p. 153.

²⁵ *Elements* I, Postulate 4, trans. Heath (note 8), p. 154.

²⁶ “The Akkadian Dialects of the Old-Babylonian Mathematical Texts”, in: MCT, pp. 146-151.

²⁷ See, beyond Goetze’s evidence, Robson, *op. cit.* (note 3), p. 278 n. 516.

Eshnunna ("group 7") and some from Susa ("group 8");²⁸ chronologically, group 7 belongs in the early eighteenth century, while groups 6 and 8 seem to be late Old Babylonian.

If the texts making use of the Pythagorean rule are located within this grid, a striking picture emerges: BM 85194, BM 85196 and VAT 6598 all belong to group 6; TMS I and XIX evidently belong to group 8; Plimpton 322, which Goetze ascribes to group 1 on the basis of very little syllabic writing, might just as well belong to group 6, where all its spellings recur. The only text which with some certainty comes from the former Sumerian South is YBC 8633, the text that does not use the rule but misapplies the 3-4-5-triangle, the author either not understanding what he is doing or not caring. All the others come from what had once constituted the periphery of Ur III, and all are late Old Babylonian (except perhaps the indeterminable Plimpton 322).

As told above, 8 texts are relevant for our discussion. So far only 7 were mentioned. The last is Db₂-146, which is from Eshnunna, dated to the reign of Ibalpiel II, year 8 or 9 – still periphery, we notice, but one of the earliest Old Babylonian mathematical texts. It deals with a rectangle whose diagonal is told to be 1°15', and whose area is 45', and thus presupposes the knowledge that the diagonal of a rectangle with sides 1 and 45' is 1°15'. The solution begins as shown in Figure 9: first the square on the diagonal is constructed; removal of twice the area (represented by four times the half-area) then leaves the square on the excess of the length over the width. Taking the "equal-side" of this square thus reduces the problem to that of a rectangle where the area and the difference between the sides is given, which

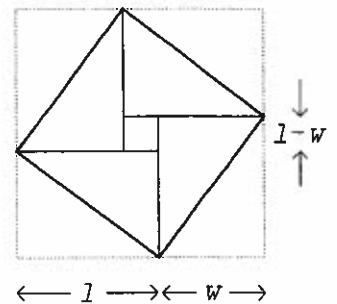

Figure 9, The initial steps of the procedure of Db₂-146.

²⁸ These numbers refer to my extension of Goetze's analysis, see Høyrup, J., "The Finer Structure of the Old Babylonian Mathematical Corpus. Elements of Classification, with some Results", to appear in: Marzahn, J. & Neumann, H. (eds), *Assyriologica et Semitica. Festschrift für Joachim Oelsner*. (AOAT, Band ?; Kevelaer & Neukirchen-Vluyn, 1999), 117-177.

is solved in the customary way.

In the solution, the text thus makes no use of the Pythagorean rule. The statement only presupposes familiarity with the standard rectangle with expressible diagonal. The procedure prescription, however, is followed by a proof, in which the diagonal is found as the equalside of the sum of the squares constructed upon the length and the width. There is thus no doubt that the rule was known in full form in Eshnunna around 1775 BC.

Transmission and transformation

As I have argued elsewhere,²⁹ this last problem belongs to a small stock of riddles that circulated among (probably) Akkadian-speaking, non-scribal surveyors in the centuries around 2000 BC. Other riddles asked for the side of a square if the sum of the measuring numbers of) either “the side” or “the four sides” and the area be given, etc. They were adopted into the new Akkadian scribe school, where they became the starting point for the development of a whole mathematical discipline (known as Old Babylonian “algebra”). When the scribe school disappeared after 1600 BC, this discipline was forgotten, but the lay tradition with its riddles survived and left its traces in Late Babylonian, Greek and Arabic mathematics. Precisely the text groups 6 and 8, however, can be seen to have been in continuous interaction with the lay tradition. There is thus no doubt that the Greek geometers encountered the Pythagorean rule when they started

²⁹ The argument is complex and cannot be recapitulated in the present context. See, for various aspects, Høyrup, J., “‘The Four Sides and the Area’. Oblique Light on the Prehistory of Algebra”, in: Calinger, R. (ed.), *Vita mathematica. Historical Research and Integration with Teaching*. (Washington, DC, 1996), 45–65 (marred by printing errors, due to the publisher’s omission of a proof reading stage); *idem*, “«Les quatre côtés et l’aire» – sur une tradition anonyme et oubliée qui a engendré ou influencé trois grandes traditions mathématiques savantes”, in: Gallo, E., L. Giacardi & C. S. Roero (eds), *Associazione Subalpina Mathesis. Seminario di Storia delle Matematiche “Tullio Viola”. Conferenze e Seminari 1995–1996* (Torino, 1996), 192–224; and *idem*, “Hero, Ps.-Hero, and Near Eastern Practical Geometry. An Investigation of *Metrica*, *Geometrica*, and other Treatises”, in: Döring, K., B. Herzhoff & G. Wöhrle (eds), *Antike Naturwissenschaft und ihre Rezeption, Band 7* (Trier, 1997), 67–93 (for obscure reasons, the publisher has changed \square into \sim and \Leftrightarrow into $\circ\ddot{\S}$ on p. 83 after having supplied correct proof sheets).

their investigation what the Near Eastern practical surveyors knew (to some extent perhaps as this knowledge had been brought to Egypt by Assyrian and Persian administrators – there is clear evidence in Demotic mathematical papyri that such borrowings took place). The Greek geometers did not restrict themselves to adoption and digestion; one of their primary aims became to understand *why* and *under which conditions* the “metrical geometry” of the surveyors worked – a process of quasi-Kantian “critique” whose results are summarized in *Elements* II.1-10. What *Elements* I.47 presents us with is a similar critique of the Pythagorean rule. This critique transforms the rule into a theorem and shows how it can be established independently of the metrical geometry of *Elements* II. In order to do that it has to make use not only of the *definition* of the right angle and of the appurtenant postulate, but also of the congruence theorems and thus of that notion of the quantified angle which the Greek geometers had created. Whereas most of the proofs of *Elements* II are easily stripped of their “critical” dress and reduced to the underlying “naive” procedures as these are described in the Babylonian texts, that of I.47 is therefore fundamentally Greek and wholly incompatible with Old Babylonian mathematical procedures and thought.

Whence?

The preceding section regards the glorious afterlife of the Old Babylonian rule. The origin of the idea cannot be established with the same certainty, but a plausible hypothesis may still be formulated.

The first observation to be made is that Figure 9 can easily be transformed into a familiar heuristic cut-and-paste proof of the rule; all we need is to prolong two of the internal lines and then to show by counting that the total area can either be described as the square on the diagonal plus twice the area of the rectangle, or as the sum of the squares on l and w and twice the rectangular area.

Next we should observe that no single source from earlier ages suggests familiarity with the rule – in particular not the Old Akkadian rectangle

problems discussed by Robert Whiting.³⁰ In contrast, an Old Akkadian text shows that the rule for bisecting a trapezium *was* known.³¹ The Old Babylonian terminology in which this rule is formulated shows that it was based on similar considerations (probably a configuration of concentric squares). *To judge from this evidence alone* it is therefore likely that the Pythagorean rule was discovered within the lay surveyors' environment, possibly as a spin-off from the problem treated in Db₂-146, somewhere between 2300 and 1825 BC. On one hand, indeed, the numerical parameters of Db₂-146 are already those of the scribe school, adapted to the sexagesimal system, and thus evidence that the adoption was not quite recent by 1775 BC; on the other, a discovery which were significantly older than 2300 BC would probably have left discernable traces in an Old Akkadian school that already had adopted other characteristic rectangle problems.

On similar though much more substantial grounds, the trick of the quadratic completion appears to have been invented in the same lay environment within the same time limits. The second-degree algebra that dumbfounded the historians of mathematics seems to be the sister of that Pythagorean rule which impressed the broader scholarly public. Since second-degree algebra penetrated the mathematics of the Old Babylonian South through and through, whereas the Pythagorean rule never impressed it perceptibly, the Pythagorean rule will have been the younger of the two, discovered somewhere in the periphery at a moment when the South was already engaged in – and perhaps had already completed – the adoption process. All in all, the discovery should thus rather be dated between 2025 (when the periphery detached itself from the Ur III empire) and 1825 BC than between 2300 and 2025.

³⁰ Whiting, R. M., "More Evidence for Sexagesimal Calculations in the Third Millennium B.C.", *ZA* 74 (1984), 59–66.

³¹ IM 58045, see Friberg, "Mathematik", in: *RIA* VII, 531–585, here 541.

ISSN 0902-901X